

URSCHEL® MODEL CC-DL

HIGH CAPACITY SHREDDER, SLICER, & STRIP CUTTER

Food processors rely on the Model CC-DL to shred, slice, strip cut, or granulate a variety of products including cheese, potatoes, other vegetables/fruits, cooked meats, and pet food. It features a large 32-inch diameter cutting zone enclosure to promote a higher capacity and diminish product build-up. The machine features continuous operation for uninterrupted production, and is designed for easy clean-up and maintenance. The Model CC-DL will accept products measuring up to 3-1/2" (88.9 mm) in any dimension.



TYPES OF CUTS

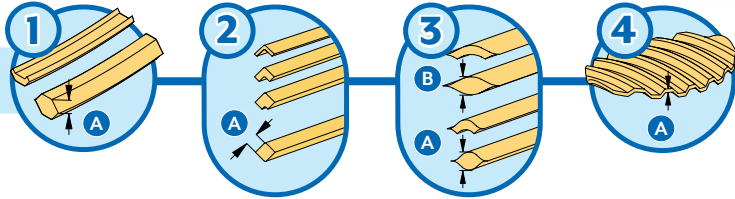

1 FULL & REDUCED FLAT-V® SHREDS

Full Flat-V Shred: Hexagonal-shaped cross section thickness (A) approximately .150" (3.8 mm) on each side using the .473 V knife.
Reduced Flat-V Shred: Flattened top and bottom that form a corrugated shred.

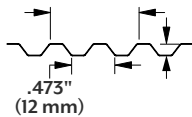

Offset .473 V knives make up each cutting station.

2 FULL SHREDS & REDUCED V SHREDS

Full Shred: Diamond-shaped cross section available in four thicknesses (A): .070" (1.8 mm) using the .125 V knife, .097" (2.5 mm) using the .170 V knife, .125" (3.2 mm) using the .212 V knife, or *.285" (7.2 mm) using the .445 V knife.
Reduced V Shred: "V"-shaped cross section

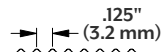

.070" (1.8 mm) Thickness
 Offset .125 V knives make up each cutting station.

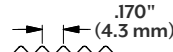

.097" (2.5 mm) Thickness
 Offset .170 V knives make up each cutting station.

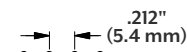

.125" (3.2 mm) Thickness
 Offset .212 V knives make up each cutting station.



***.285" (7.2 mm) Thickness**
 Offset .445 V knives make up each cutting station.

3 OVAL & REDUCED OVAL (CRESCENT) SHREDS

Oval Shred: Oval-shaped cross section (A) approximately .125" (3.2 mm) thick by .250" (6.4 mm) wide using the .300 crinkle knife.
Wide Oval Shred: Wide oval-shaped cross section (B) .125" (3.7 mm) thick by .375" (9.5 mm) wide using the .480 crinkle knife.
Crescent Shred: Crescent-shaped cross section.
Wide Crescent Shred: Wide crescent-shaped cross section.

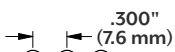

.125" (3.7 mm) thick x .250" wide (6.4 mm) Oval Shred
 Offset .300 crinkle knives make up each cutting station.

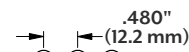

.125" (3.7 mm) thick x .375" wide (9.5 mm) Wide Oval Shred
 Offset .480 crinkle knives make up each cutting station.

4 *FLAT-V® SLICES
 Slice thickness (A) range of .040"-.180" (1.0-4.6 mm) with 2.1 (25.4 mm) corrugations per inch. Corrugation depth of .125" (3.2 mm); Center depth: .473" (12 mm).

5 **Z-CUT SLICES
 Slice thickness (A) range is .030"-.115" (0.8 - 2.9 mm) with 2.54 corrugations per inch (25.4 mm). Corrugation depth is .135" (3.4 mm); Center depth: .394" (10 mm).

6 V SLICES
 Slice thickness (A) range is .040" (1.0 mm) to .500" (12.7 mm) available in two different "V" depths:
.125" Slice: 8 "V"s per inch, "V" depth of .050" (1.3 mm), Center depth: .125" (3.2 mm).
.212" Slice: 4.7 "V"s per inch, "V" depth of .084" (2.1 mm), Center depth: .212" (5.4 mm).

7 CRINKLE SLICES
 Slice thickness (A) range is .040" (1.0 mm) to .500" (12.7 mm). Available in three different crinkle depths:
.175" Slice: Crinkle depth .084" (2.1 mm), Center depth .175" (4.4 mm),
.300" Slice: Crinkle depth .080" (2.0 mm), Center depth .300" (7.6 mm),
.480" Slice: Crinkle depth .076" (1.9 mm), Center depth .480" (12.2 mm).

8 FLAT SLICES
 Slice thickness (A) range is .030" (0.8 mm) to .500" (12.7 mm).

9 STRIP CUTS
 Rectangular cross section available in a variety of widths (A): 3/32, 1/8, 3/16, 1/4, 1/2, or 3/4" (2.4, 3.2, 4.8, 6.4, 12.7, or 19.1 mm)

10 GRATING OPTIONS
 Grating heads offer cuts including powdered parmesan, coarse granules, and a variety of shreds.

*Limited availability based on customer application. Contact your local Urschel office to verify salability.
 **Z-Cut is only available in non-European countries.

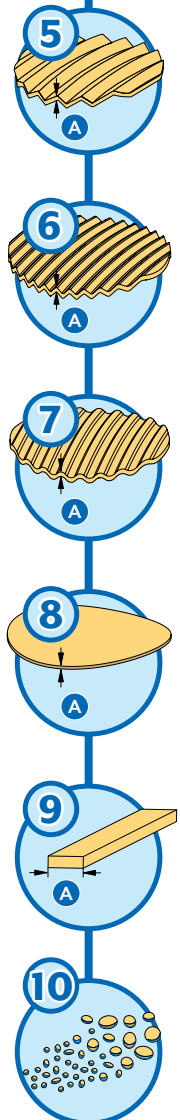

MicroAdjustable® SH-14 & SL-14 heads offer increased capacity with 14 cutting stations versus the standard 8 head. To determine the availability of specific thicknesses and styles, visit www.urschel.com.

URSCHEL® MODEL CC-DL

Measurements and weights may vary depending on machine configuration.

Length:..... 61.66" (1566 mm)

Net Weight: ..700 lb (318 kg)

Width:..... 35.60" (904 mm)

Motor:.....10 HP (7.5 kW)

Height: 33.89" (861 mm)



CUTTING OVERVIEW

1. Impeller Paddle
2. Shredding Knife

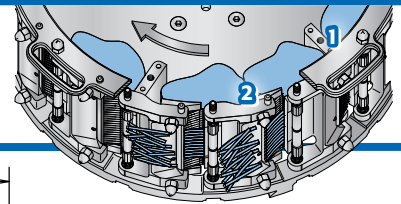

SPECIFICATIONS & DIMENSIONS

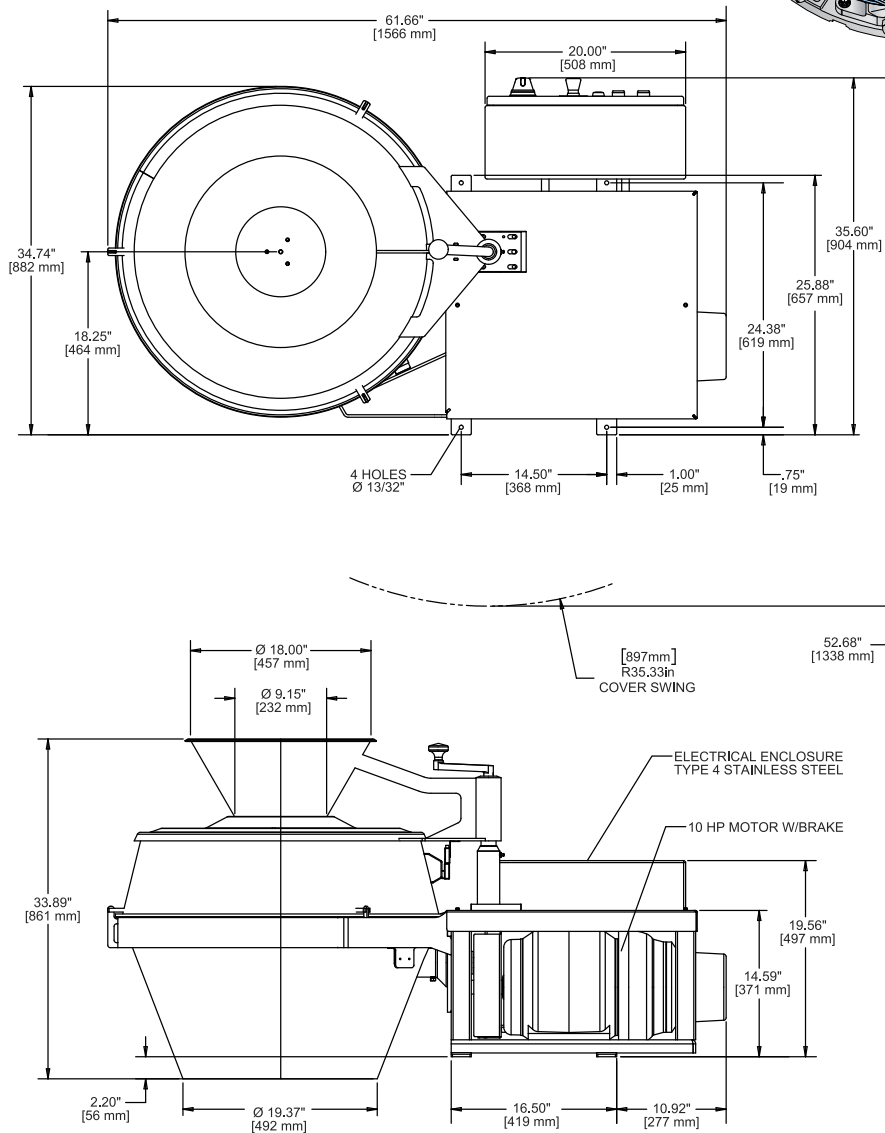

TEST CUT YOUR PRODUCT

Contact your local Urschel representative to schedule a comprehensive, no-obligation test-cut of your product: www.urschel.com.



URSCHEL®

The Global Leader in Food Cutting Technology

www.urschel.com | info@urschel.com

If your product application is not mentioned on this page, contact your local Urschel representative to determine the most effective solution to your size reduction needs.

© Urschel logo symbol, Urschel, The Global Leader in Food Cutting Technology, and Flat-V are registered trademarks of Urschel Laboratories, Inc.

L3637 MAR 2021 (s.s. L3320)