

URSCHEL® MODEL CCX-D

HIGH CAPACITY VERSATILE SHREDDER, SLICER, & STRIP CUTTER

The Model CCX-D Shredder (MCCXD) features a large 32" (813 mm) diameter cutting zone. This large cutting zone combined with the 10 horsepower motor promotes a higher capacity and lessens product build-up. The machine is also available with a 24" (610 mm) diameter cutting enclosure. **New 2-piece enclosure allows easy access for complete cleaning and maintenance.** The versatile CCX-D features interchangeable quick locking double ring, single adjustment cutting heads enabling the changeover to different cuts in just minutes. Specially designed knives do not require sharpening, and are inexpensive to replace. To promote sanitation, the machine features an attached swingaway feed hopper, hinged access panels, sloped surfaces, and stainless steel highly polished to U.S.D.A., Dairy Division accepted standards. The machine features continuous operation for uninterrupted production, and is designed for easy clean-up and maintenance. The Model CCX-D will accept products measuring up to 3-1/2" (88.9 mm) in any dimension.



TYPES OF CUTS

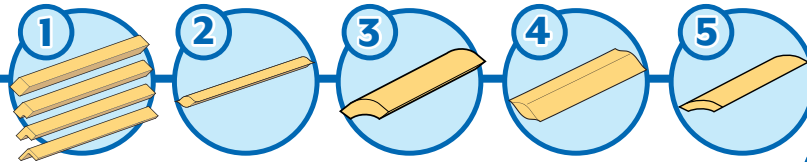

1 FULL SHREDS & REDUCED V SHREDS

Full Shred: Diamond-shaped cross section available in four thicknesses: .070, .097, .125, or * .285" (1.8, 2.5, 3.2, or *7.2 mm).

Reduced V Shred: "V"-shaped cross section

2 OVAL SHREDS

.250" Oval Shred: Oval-shaped cross section approximately .125" (3.2 mm) thick by .250" (6.4 mm) wide.

3 CRESCENT SHREDS

Crescent-shaped cross section.

4 † WIDE OVAL SHREDS

.480" Wide Oval Shred: .152" (3.7 mm) thick by .480" (12.2 mm) wide.

5 † WIDE CRESCENT SHREDS

Wide crescent-shaped cross section

6 † FULL & REDUCED FLAT-V® SHREDS

Full Flat-V Shred: Hexagonal-shaped cross section approximately .150" (3.8 mm) on all sides.

Reduced Flat-V Shred: Flattened top and bottom that form a corrugated shred.

7 FLAT SLICES

Slice thickness up to .500" (12.7 mm)

8 † FLAT-V® SLICES

Slice thickness up to .180" (4.6 mm) with 2.1 corrugations per inch. Corrugation depth of .125" (3.2 mm); Centers: .473" (12 mm).

9 † **Z-CUT SLICES

Slice thickness up to .325" (8.3 mm) with 2.1 corrugations per inch. Corrugation depth of .135" (3.4 mm); Centers: .394" (10 mm)

10 † V SLICES

Slice thickness up to .500" (2.5 mm)

.125" Slice: 8 complete "V"s per inch. "V" depth of .050" (1.3 mm); Centers: .125" (3.2 mm).

.212" Slice: 4.7 "V"s per inch. "V" depth of .084" (2.1 mm); Centers: .212" (5.4 mm)

11 † CRINKLE SLICES

Slice thickness up to .500" (12.7 mm) with 3-1/2 waves per inch.

.175" Slice: Crinkle Depth .084" (2.1 mm), Centers .175" (4.4 mm),

.300" Slice: Crinkle Depth .080" (2.0 mm), Centers .300" (7.6 mm).

.480" Slice: Crinkle Depth .076" (1.9 mm), Centers .480" (12.2 mm).

12 † STRIP CUTS

Rectangular cross section.

Width: 3/32, 1/8, 3/16, 1/4, 3/8, 1/2, 9/16, or 3/4" (2.4, 3.2, 4.8, 6.4, 9.5, 12.7, 14.3, or 19 mm)

13 † GRATING OPTIONS

Grating heads offer cuts including powdered parmesan, coarse granules, and a variety of shreds.

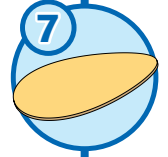

*Limited availability based on customer application. Contact your local Urschel office to verify salability.

**The Z-Cut is only available in non-European countries.

† Not all components in these cut types may be available in highly polished U.S.D.A., Dairy Division accepted stainless steel finish.

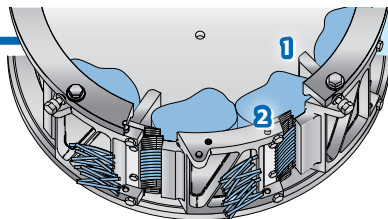

CUTTING OVERVIEW

1. Impeller Paddle
2. Shredding Knife

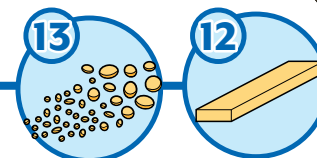

URSCHEL® MODEL CCX-D

Measurements and weights may vary depending on machine configuration.

Length:..... 58.78" (1493 mm), 24" diam. encl.
 66.28" (1684 mm), 32" diam. encl.

Net Weight: ..1,000 lb (454 kg)

Width:..... 32.95" (837 mm)

Motor:.....10 HP (7.5 kW)

Height:..... 31.61" (803 mm), 24" diam. encl.
 34.11" (866 mm), 32" diam. encl.

The Model CCX-D is accepted by the U.S.D.A, Dairy Division.



SPECIFICATIONS & DIMENSIONS

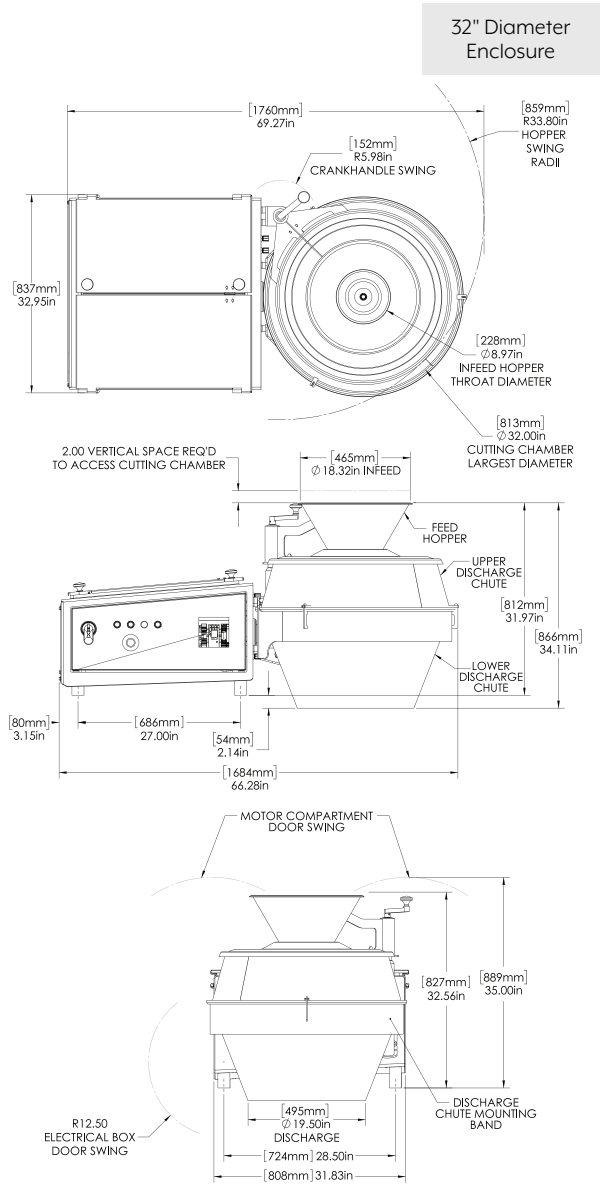
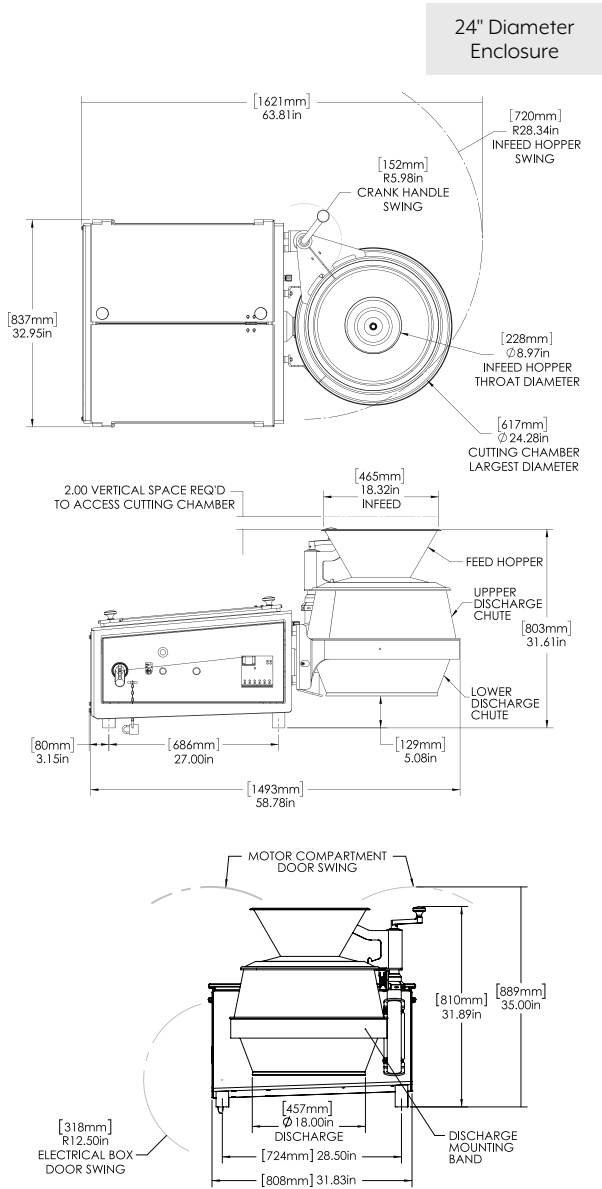

The Model CCX-D (both 24" and 32" diameter enclosures) are available with an optional caster frame. Dimensions will vary depending on customer requirements. Contact your local Urschel representative for additional information.

TEST CUT YOUR PRODUCT

Contact your local Urschel representative to schedule a comprehensive, no-obligation test-cut of your product: www.urschel.com.



URSCHEL®

The Global Leader in Food Cutting Technology

www.urschel.com | ✉ info@urschel.com