

URSCHEL® MODEL CC-D

VERSATILE SHREDDER, SLICER, & STRIP CUTTER

Food processors choose the Model CC-D to shred, slice, strip cut, or granulate a variety of products including cheese, coconut, cranberries, potatoes, other fruits/vegetables, cooked meats, surimi, and pet food. Available in all stainless steel, the machine features continuous operation for uninterrupted production, and is designed for easy clean-up and maintenance. The Model CC-D will accept products measuring up to 3-1/2" (88.9 mm) in any dimension.



TYPES OF CUTS

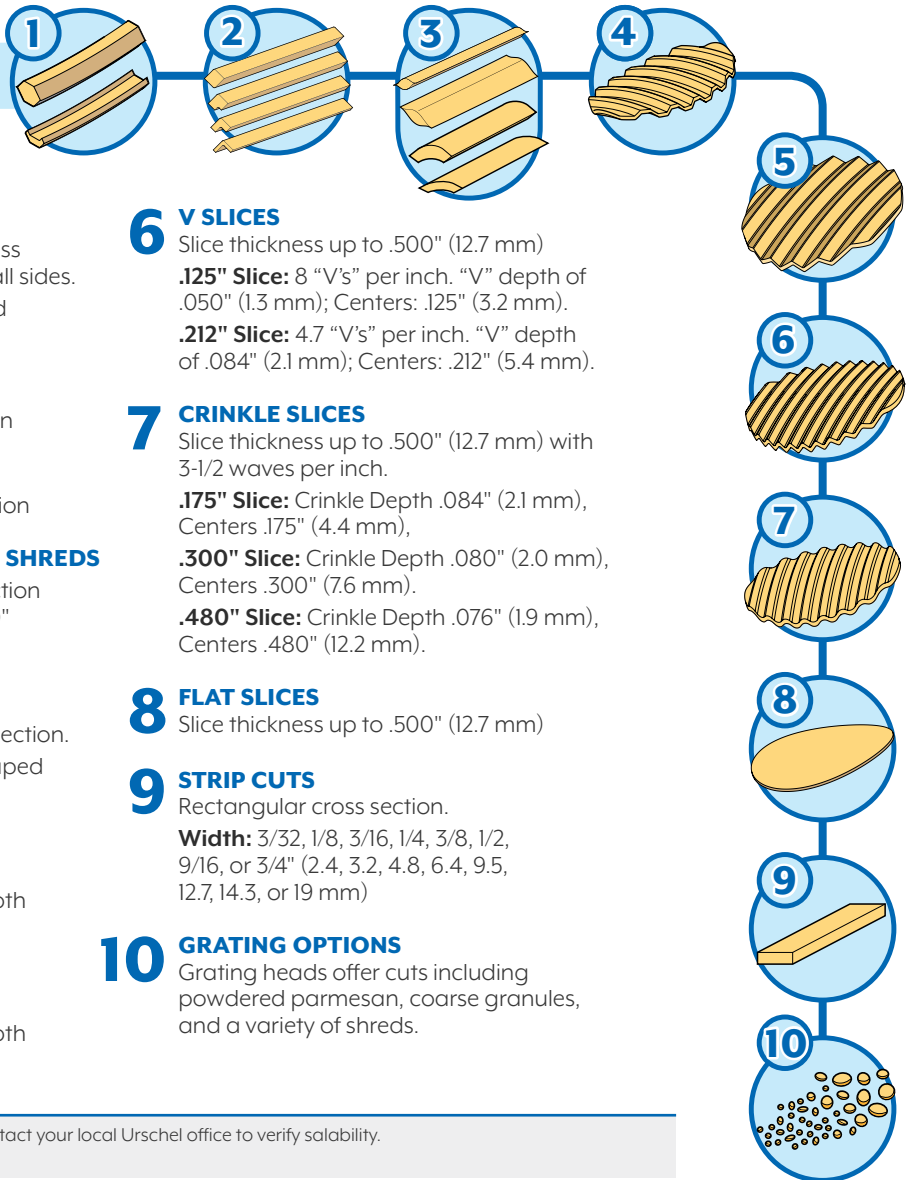

1 FULL & REDUCED FLAT-V® SHREDS

Full Flat-V Shred: Hexagonal-shaped cross section approximately .150" (3.8 mm) on all sides.
Reduced Flat-V Shred: Flattened top and bottom that form a corrugated shred.

2 FULL SHREDS & REDUCED V SHREDS

Full Shred: Diamond-shaped cross section available in four thicknesses: .070, .097, .125, or *.285" (1.8, 2.5, 3.2, or *7.2 mm).
Reduced V Shred: "V"-shaped cross section

3 OVAL & REDUCED OVAL (CRESCENT) SHREDS

.250" Oval Shred: Oval-shaped cross section approximately .125" (3.2 mm) thick by .250" (6.4 mm) wide.
.480" Wide Oval Shred: .152" (3.7 mm) thick by .480" (12.2 mm) wide.
Crescent Shred: Crescent-shaped cross section.
Wide Crescent Shred: Wide crescent-shaped cross section.

4 *FLAT-V® SLICES

Slice thickness up to .180" (4.6 mm) with 2.1 corrugations per inch. Corrugation depth of .125" (3.2 mm); Centers: .473" (12 mm).

5 **Z-CUT SLICES

Slice thickness up to .325" (8.3 mm) with 2.1 corrugations per inch. Corrugation depth of .135" (3.4 mm); Centers: .394" (10 mm).

6 V SLICES

Slice thickness up to .500" (12.7 mm)
.125" Slice: 8 "V's" per inch. "V" depth of .050" (1.3 mm); Centers: .125" (3.2 mm).
.212" Slice: 4.7 "V's" per inch. "V" depth of .084" (2.1 mm); Centers: .212" (5.4 mm).

7 CRINKLE SLICES

Slice thickness up to .500" (12.7 mm) with 3-1/2 waves per inch.
.175" Slice: Crinkle Depth .084" (2.1 mm), Centers .175" (4.4 mm),
.300" Slice: Crinkle Depth .080" (2.0 mm), Centers .300" (7.6 mm).
.480" Slice: Crinkle Depth .076" (1.9 mm), Centers .480" (12.2 mm).

8 FLAT SLICES

Slice thickness up to .500" (12.7 mm)

9 STRIP CUTS

Rectangular cross section.
Width: 3/32, 1/8, 3/16, 1/4, 3/8, 1/2, 9/16, or 3/4" (2.4, 3.2, 4.8, 6.4, 9.5, 12.7, 14.3, or 19 mm)

10 GRATING OPTIONS

Grating heads offer cuts including powdered parmesan, coarse granules, and a variety of shreds.

*Limited availability based on customer application. Contact your local Urschel office to verify salability.
**Z-Cut is only available in non-European countries.

CUTTING OVERVIEW

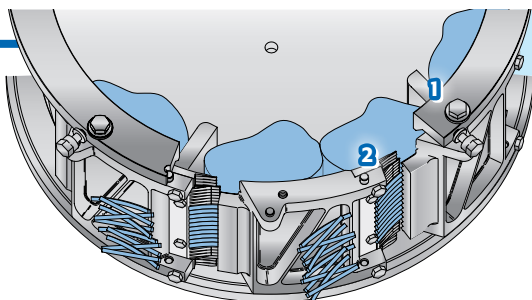

1. Impeller Paddle
2. Shredding Knife

If your product application is not mentioned on this page, contact your local Urschel representative to determine the most effective solution to your size reduction needs.

URSCHEL® MODEL CC-D

Measurements and weights may vary depending on machine configuration.

Length:..... 48.03" (1220 mm) - 5 HP
 51.74" (1314 mm) - 10 HP

Net Weight: .. 550 lb (250 kg) - 5 HP
 680 lb (310 kg) - 10 HP

Width:..... 35.59" (904 mm)

Motor:..... 5 or 10 HP (3.7, or 7.5 kW)

Height:..... 29.92" (760 mm) - 5 HP
 31.36" (797 mm) - 10 HP



SPECIFICATIONS & DIMENSIONS

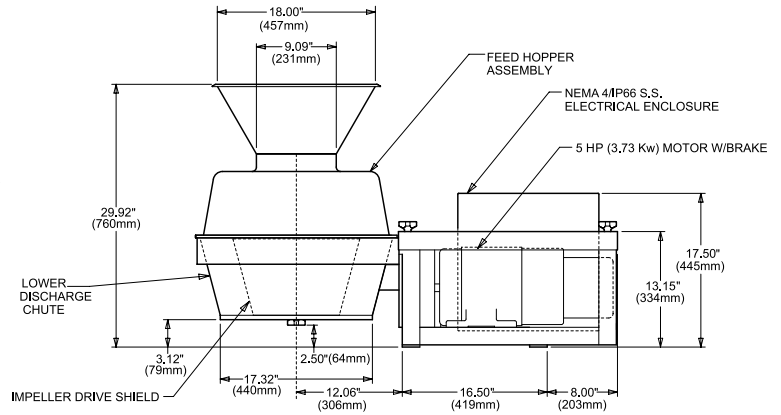
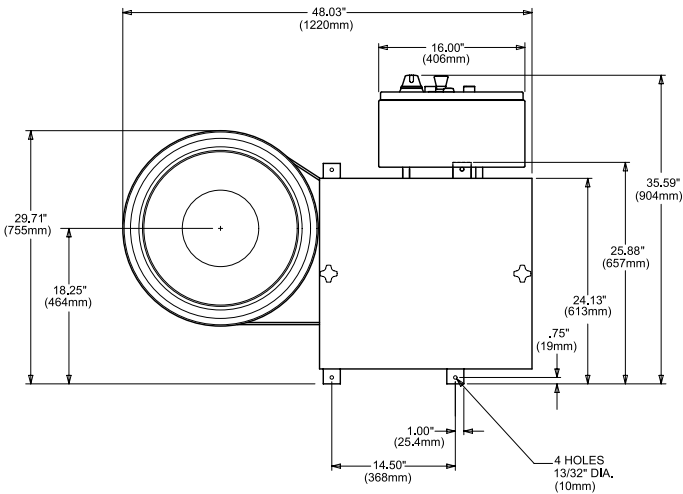

Model CC-D equipped with a 5 HP motor

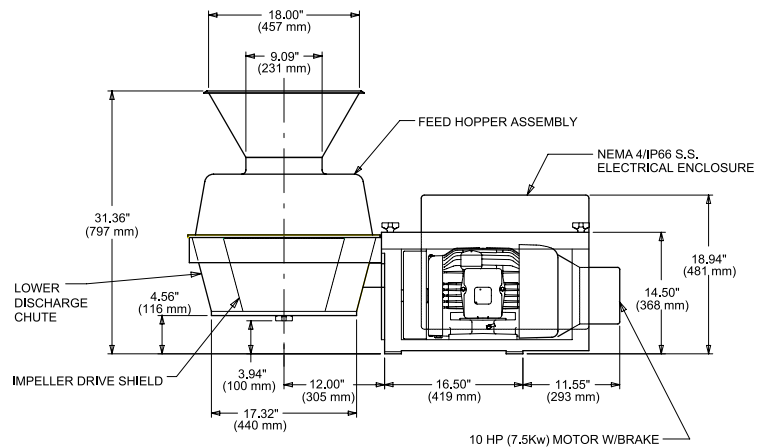
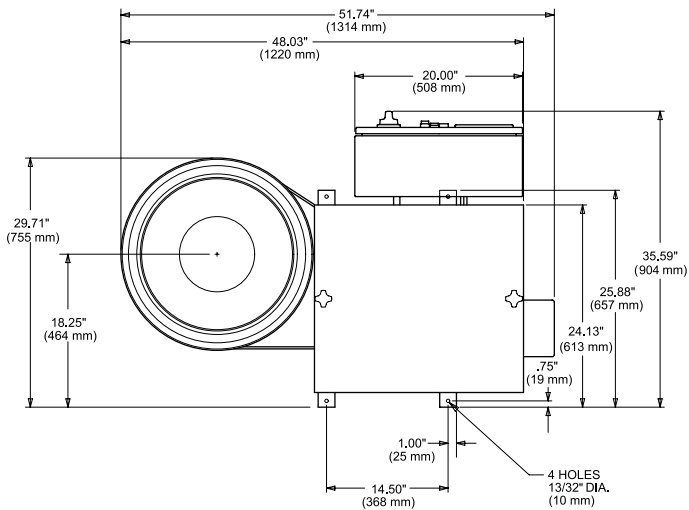

Model CC-D equipped with a 10 HP motor

TEST CUT YOUR PRODUCT

Contact your local Urschel representative to schedule a comprehensive, no-obligation test-cut of your product: www.urschel.com.



URSCHEL®

The Global Leader in Food Cutting Technology

www.urschel.com | info@urschel.com