

DIVERSACUT 2110A[®] DICER LARGE PRODUCT INPUT

FOR WHOLE HEADS OF LEAFY VEGETABLES

Urschel delivers a targeted solution to processing leafy products – the DiversaCut 2110A[®] Dicer specially equipped with a large feed hopper and new type of impeller. Working with leading fresh cut processors, this new development alleviates precutting and minimizes product handling. This DiversaCut 2110A Large Product Input (MDCA, LPI) accepts products as large as 14" (356 mm) in diameter. This machine is available through our Engineering Certified Print Program – a specialty service geared toward producing ideal machines for individual processing lines/configurations. This machine is designed to interlock with product takeaway devices.



TYPES OF CUTS

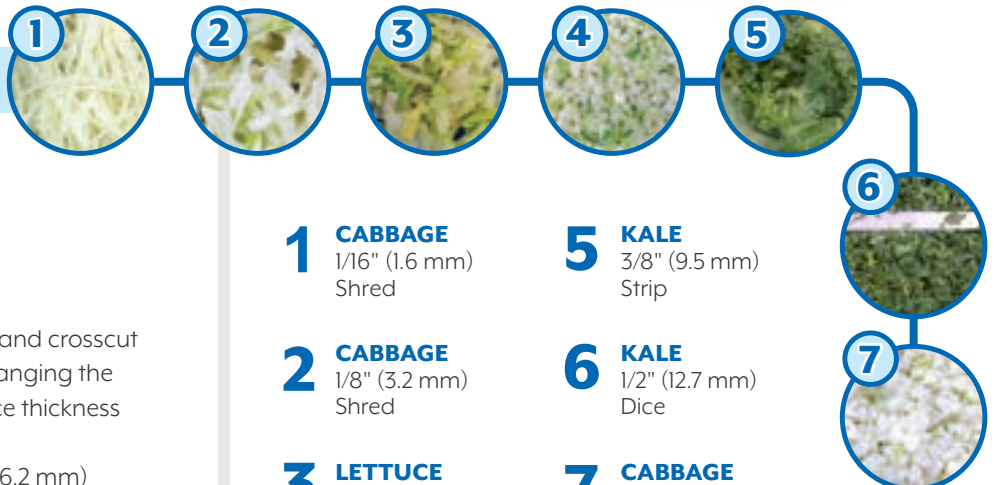

SLICES

Slice thickness: up to 1" (25.4 mm)

DICES

A slicing knife, circular knife spindle, and crosscut knife spindle are used for dicing. Changing the dice size is done by adjusting the slice thickness and cutting spindles as needed.

Circular Knife Cuts: 1/8 – 3" (3.2 – 76.2 mm)

Crosscut Knife Cuts: 3/32 – 1-1/2" (2.4 – 38.1 mm)

STRIP CUTS/SHREDS

Flat strips can be made by removing either the crosscut knife spindle or the circular knife spindle. Combinations of circular knives or crosscut knives can be used to shorten the length of the strips.

1 CABBAGE
1/16" (1.6 mm)
Shred

5 KALE
3/8" (9.5 mm)
Strip

2 CABBAGE
1/8" (3.2 mm)
Shred

6 KALE
1/2" (12.7 mm)
Dice

3 LETTUCE
1/4" (6.4 mm)
Shred

7 CABBAGE
1/4" (6.4 mm)
Dice

4 CABBAGE
1/4 x 3/16 x 1/4"
(6.4 x 4.8 x
6.4 mm) Dice

CUTTING OVERVIEW

1. Slice Adjustment Knob
2. Impeller Paddles
3. Slicing Knife
4. Circular Knives
5. Crosscut Knives

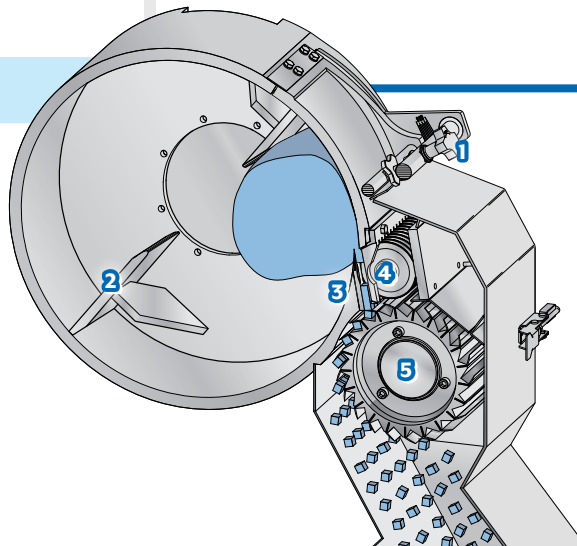

If your product application is not mentioned on this page, contact your local Urschel representative to determine the most effective solution to your size reduction needs.

DIVERSACUT 2110A[®] DICER WITH LARGE PRODUCT HOPPER

Measurements and weights may vary depending on machine configuration.

Length:.....69.22" (1758 mm) **Net Weight:**.....1700 lb (770 kg)
 Width:.....56.22" (1428 mm) **Motor:**.....5 HP (3.7 kW) with VFD
 Height:.....70.31" (1786 mm)



SPECIFICATIONS & DIMENSIONS

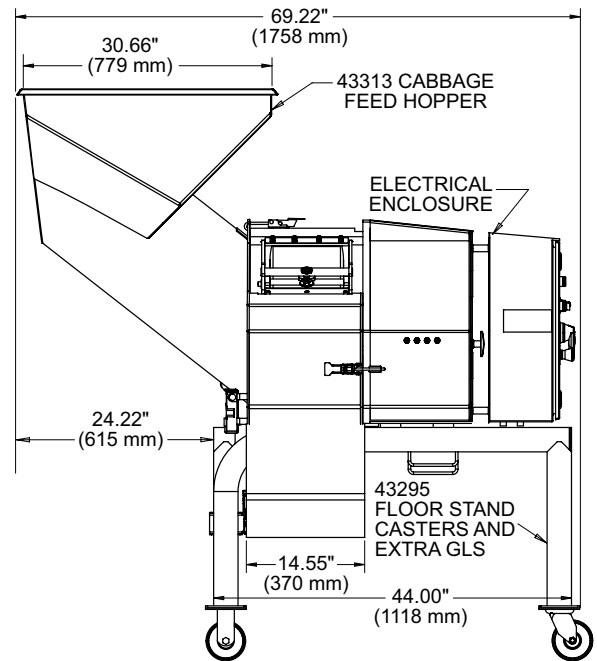
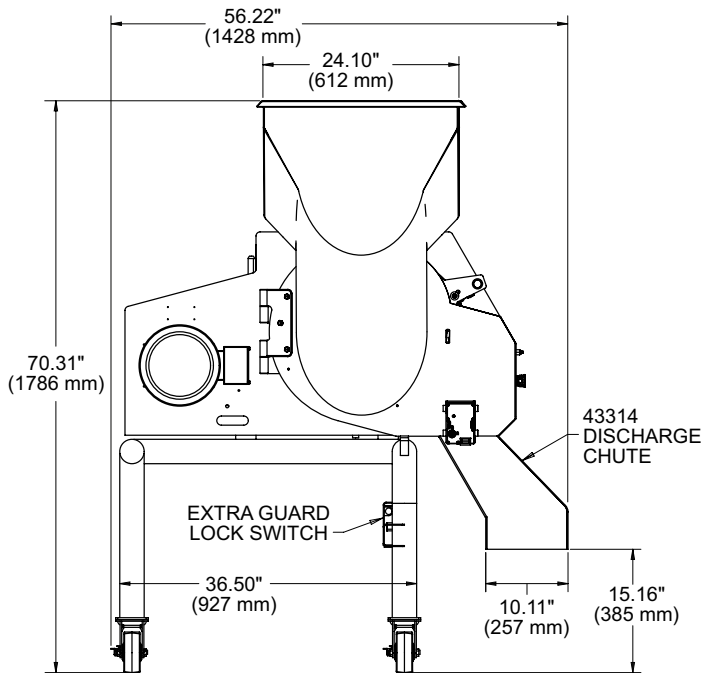
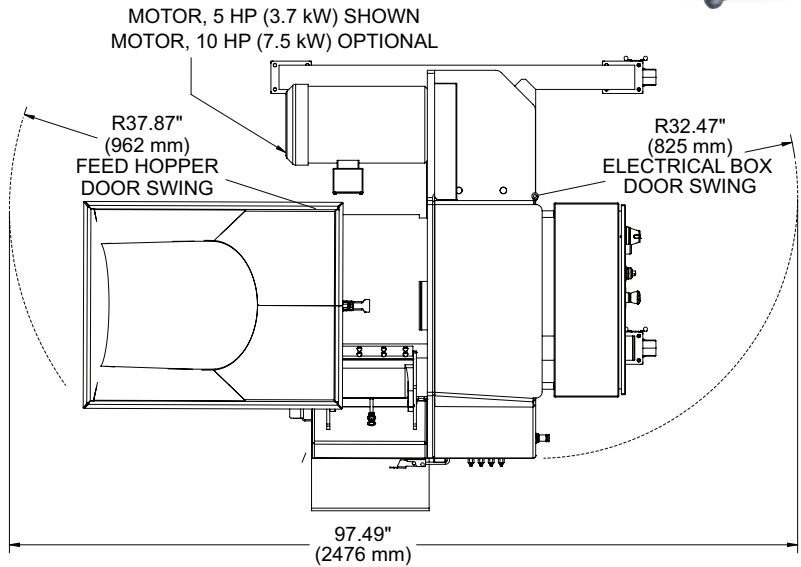

TEST CUT YOUR PRODUCT

Contact your local Urschel representative to schedule a comprehensive, no-obligation test-cut of your product: www.urschel.com.



URSCHEL[®]
 The Global Leader in Food Cutting Technology

www.urschel.com | ✉ info@urschel.com