

# COMITROL® PROCESSOR MODEL 9310 WITH FEEDER

## HIGH CAPACITY, CONTROLLED PARTICLE SIZE REDUCTION

The patented Comitrol Processor Model 9310 replaces the model 9300. Features include an integrated HMI, improved airflow system, newly designed cutting enclosure, and an extended shaft spindle. Integrated standard HMI monitors amperage, temperature of the motor bearings and inside air of the support housing, identifies misaligned safety sensors, and flags machine runtime, motor loads, and overfeeding issues. The airflow system incorporates a new screened-in fan within a support housing working to consistently cool the motor and belt and deter the support housing from thermally expanding. Air ducts divert warm air away from the product zone. Stainless steel mesh on fan screen may be easily removed for routine cleaning.

Robust cutting enclosure is contoured to alleviate product pressure inside the impeller with seals firmly seated for containment of processed products. Different bolt-on discharge designs are available to suit different production lines. Extended shaft spindle inserts additional space between the spindle and cutting enclosure and maintains a primary and labyrinth seal to deter product from entering the spindle bearings. It is also outfitted with a bypass to prevent build-up and back-up of product. The Comitrol Processor Model 9310 is recommended for particle size reduction when the final product will be a slurry, paste, or liquid. Equipped with a 12" (305 mm) microcut head and impeller, the 9310 is designed for one-pass size reduction due to the rapid velocity speed of the impeller. Vegetables, fruits, and meats for baby food, as well as nut milks and butters are routinely processed implementing this machine.



### TYPES OF CUTS



#### Microcut Head

Utilizes 12" (304.8 mm) diameter Microcut Head to produce particle sizes ranging from coarse to fine emulsions. To ensure the proper combination of cutting parts, Urschel recommends a free-of-charge test cut of your application. Contact Urschel for more information.

<b>1</b> ALMOND MILK	<b>7</b> SOY MILK
<b>2</b> DELI MUSTARD	<b>8</b> VEGETABLE JUICE
<b>3</b> BABY FOOD	
<b>4</b> PEANUT BUTTER	
<b>5</b> HOT SAUCE	
<b>6</b> PHARMACEUTICAL MILLING	

*NOTE: Products that are explosive or create a potentially explosive atmosphere should not be processed by any standard Urschel machine. A potentially explosive atmosphere could be created if processing your product creates fumes or dust in sufficient concentrations. In such cases, customers may work with Urschel to develop a customized solution through a certified print (CP) process.*

### CUTTING OVERVIEW

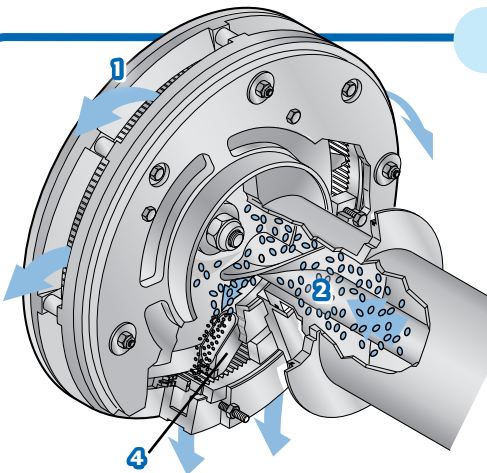

1. Microcut Head
2. Feed Screw
3. Microcut Blades
4. Impeller

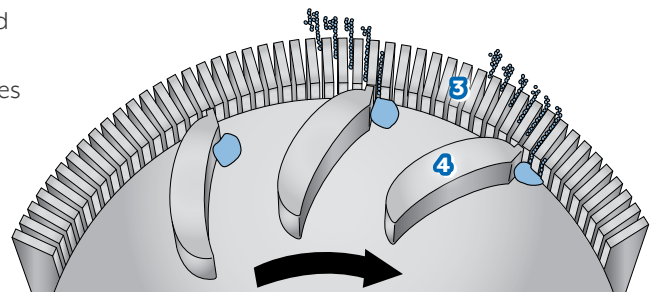

If your product application is not mentioned on this page, contact your local Urschel representative to determine the most effective solution to your size reduction needs.

# COMITROL® PROCESSOR MODEL 9310 WITH FEEDER

Measurements and weights may vary depending on machine configuration.

<b>Length:</b> .....	107.00" (2718 mm)	.....	Screw Feeder
<b>Width:</b> .....	60.90" (1547 mm)		equipped with a
<b>Height:</b> .....	94.00" (2388 mm)		gearmotor and
<b>Net Weight:</b> .....	4000 lb (1814 kg)		VFD (variable
<b>Motors:</b> .....	150 or 200 HP		frequency drive) –
	(112 or 149.1 kW)		2 HP (1.5 kW)

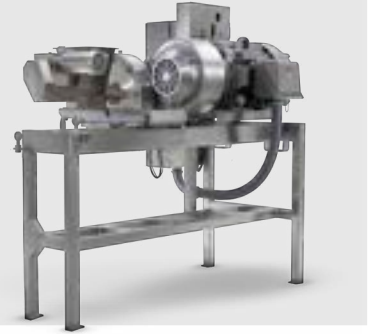

SPECIFICATIONS & DIMENSIONS

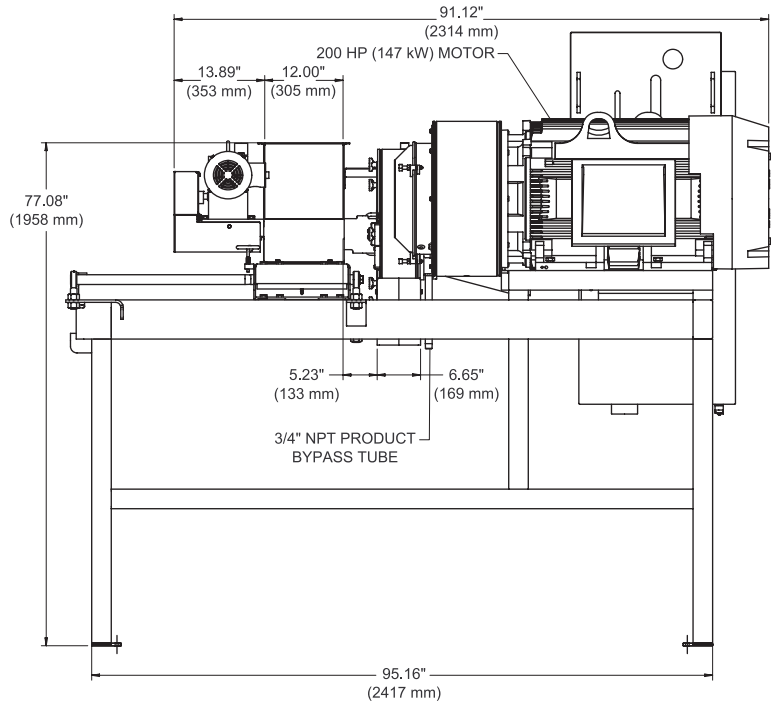
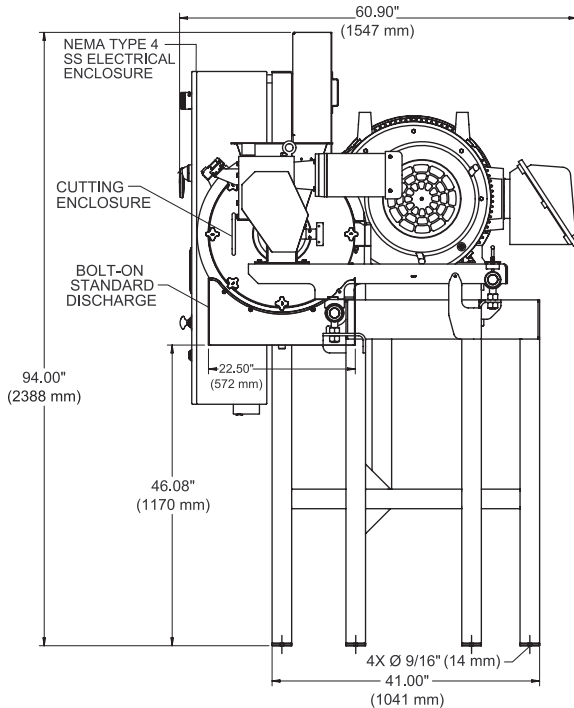
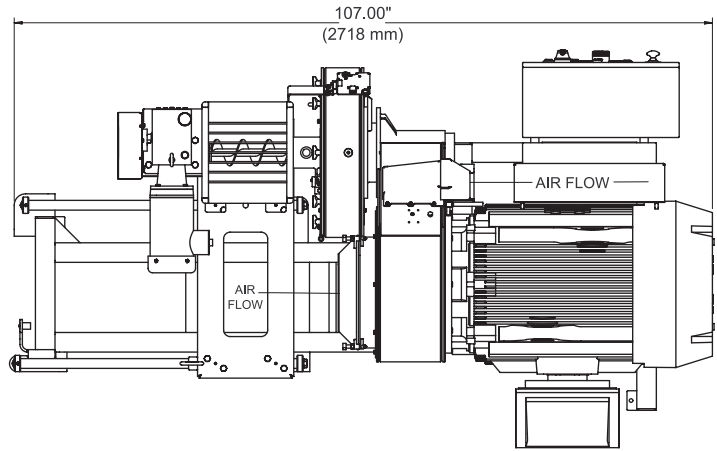
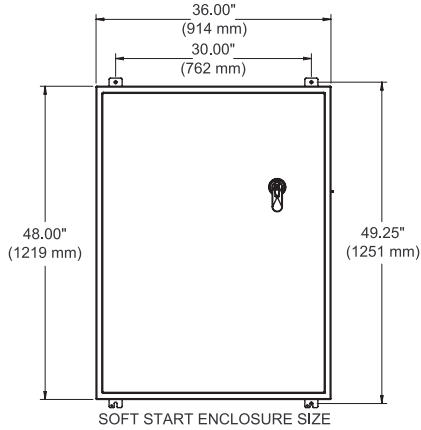

**PUT URSCHTEL TO THE TEST** Schedule a comprehensive, no-obligation test cut of your product.

**COMITROL®**  
BY URSCHTEL THE SIZE REDUCTION SPECIALISTS

**URSCHTEL®**  
The Global Leader in Food Cutting Technology  
www.urschel.com | info@urschel.com