

Urschel® Model RA-A

Uniformly Dice, Strip Cut, or Slice

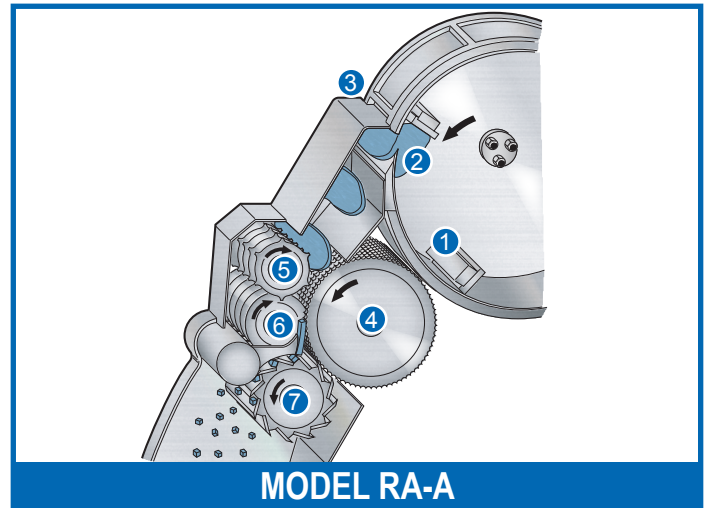

SPECIFICATIONS

Length: 46.11" (1171 mm)
 Width: 36.93" (938 mm)
 Height: 71.39" (1833 mm)
 Net Weight: 700 lb (317.5 kg)
 Motor: 5 HP (3.7 kW)

APPLICATIONS

The Model RA-A produces a wide range of dices and strip cuts from a variety of products such as fruits, vegetables, products for relish, nuts, and processed meats. Maximum input product is 3-1/2" (88.9 mm) in any dimension. The Model RA-A features continuous operation for uninterrupted production and is designed for easy cleanup and maintenance.



Model RA-A with optional stainless steel motor and castor frame.

OPERATING PRINCIPLE

Product delivered to the feed hopper continues into a rotating impeller. Centrifugal force holds the product against the inside of the slice case as the impeller paddles [1] carry the product past the slicing knife [2]. An adjustable case gate [3] at the front of the case allows the product to move forward across the edge of the slicing knife. The opening between the end of the case gate and the slicing knife edge determines the slice thickness. Slices then drop onto a revolving feed drum [4]. The drum and an opposing feed spindle [5] transfer the slices to the circular knife spindle [6] where the product is cut into strips. The strips then move directly into the rotating crosscut knives [7] producing cubes or rectangular pieces of predetermined size.

TYPES OF CUTS

DICES: A slicing knife, circular knife spindle, and crosscut knife spindle are used for dicing. Changing the size of the cubes is done by using the required cutting spindles and adjusting the slice thickness.

Slice thickness: 1/16 to 3/8" (1.6 to 9.5 mm)

Circular Knife Cuts: 1/8 to 1" (3.2 to 25.4 mm)

Crosscut Knife Cuts: .05 to 3" (1.3 to 76.2 mm)

STRIP CUTS: Removal of crosscut knife spindle and shaft will enable the user of the RA-A to produce strips of different lengths as determined by incoming product size. A circular spindle change may also be required.

If your product application is not mentioned on this page, contact your local Urschel representative to determine the most effective solution to your size reduction needs.

Urschel® Model RA-A Dimensional Drawing

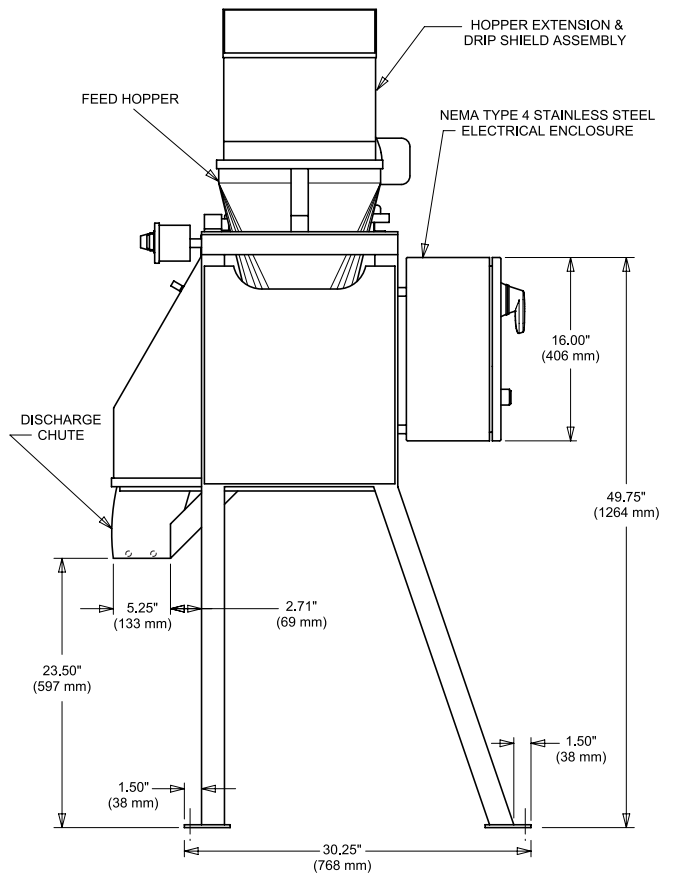
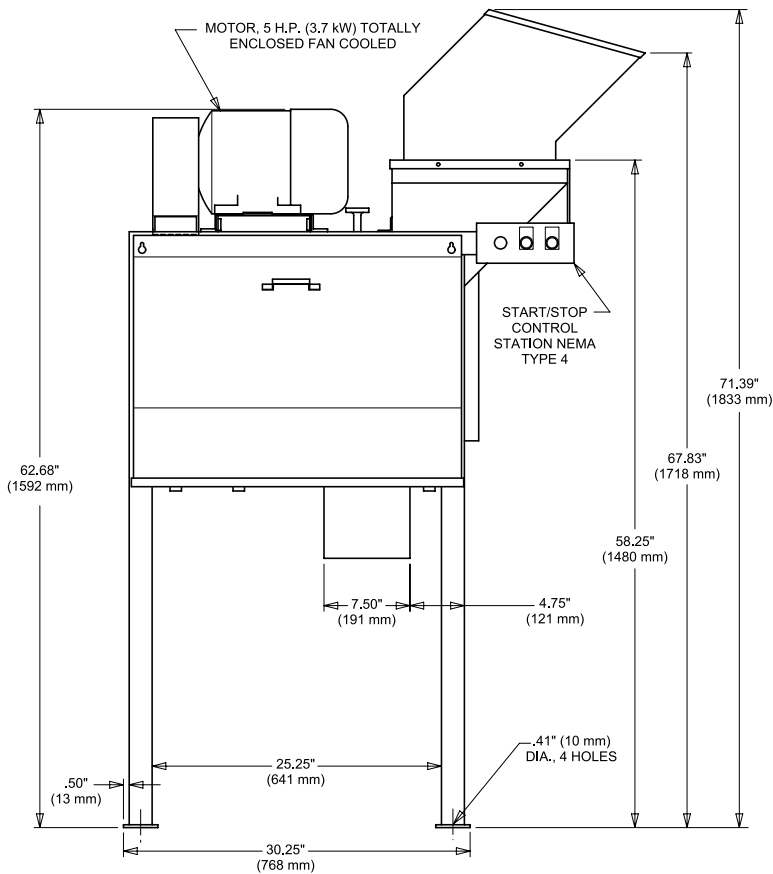
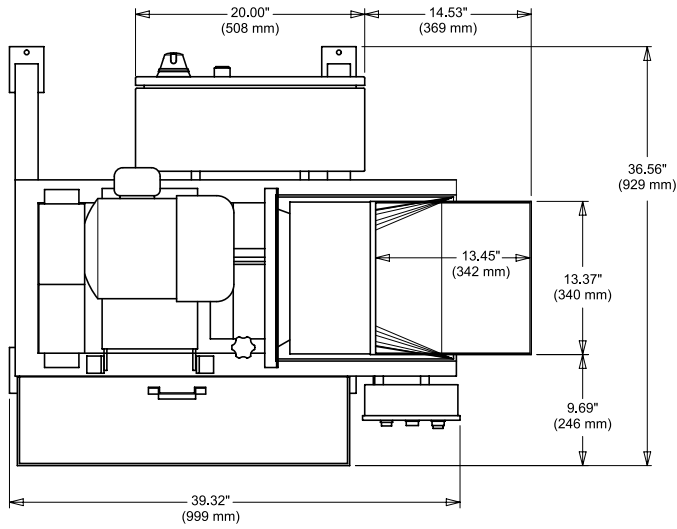

You Are Invited to Test Cut Your Product

Urschel Laboratories has a complete network of test facilities and experienced service and sales representatives around the world ready to work for you on any size reduction application. Contact your local Urschel Laboratories' representative to schedule a comprehensive, no-obligation test today at www.urschel.com.



URSCHTEL
LABORATORIES INCORPORATED
The Global Leader in Food Cutting Technology

www.urschel.com | info@urschel.com