

Rapid-Dry, Timesaving **KS-100 Plus**

The KRONEN KS-100 PLUS vegetable and lettuce spin-dryer can be integrated into processing lines or used as a stand-alone machine. The KS-100 PLUS is used by customers worldwide to spin-dry a wide variety of products including lettuce, cut vegetables, and fruit. Washed products are filled into the spin baskets and manually placed into the dryer and manually removed upon process completion.

Maximum product weight/fill quantity is 22 lb (10 kg). Maximum hourly capacity up to 2,755 lb (1,250 kg) per hour dependent on product.



MAX CAPACITY
2,755
Pounds/Hour

SPIN DRYER

STORE UP TO
100
Memory Options



Your Partner in Processing Line Solutions

Urschel, The Global Leader in Food Cutting Solutions, continues to assist commercial and industrial size food processors everywhere.

Reaching out to assist processors of all sizes, Urschel now provides KRONEN systems.

KRONEN systems are backed by high quality Urschel service and expertise.



KS-100 Plus

SPIN DRYER

Features

Simple to operate, fast-dry technology.

The provided plastic basket is integral to the successful operation of the dryer.

The volume of the plastic basket must be filled evenly with product. Fill level must be such that the product cannot emerge from the basket while spinning.

Designed for commercial kitchen use taking up limited floor space.

Can be integrated into a processing line, downstream of the washing

process, or used as a stand-alone machine.

Low lift-in height leads to ergonomic operation for the user.

Optimal hygiene without dirt traps or screws in the spinning area.

Streamlined water drainage design.

Up to 100 programmable memory options to store different types of products to be ready at a push of a button.



Applications

- ✔ Drying of lettuce, herbs, cut fruit, vegetables, and other products.
- ✔ Reduce draining times of canned products such as mushrooms, pickled vegetables, or defrosted products.
- ✔ Dewater/dry prawns, caviar, or sesame seeds and similar products.
- ✔ Mesh inserts available for fine-particle products.

3 Easy Steps

1. Open dryer hood by lifting the cover and ensure the machine interior is fully clean.
2. Securely insert provided plastic basket loaded with up to 20 lb (10 kg) of evenly distributed product.
3. Close the dryer hood and follow designated operating manual procedures with your programmed dedicated selections.

Accessories

- ✔ Basket slide for connecting from a KRONEN washing machine to the spin-dryer.
- ✔ Basket Carousel for continuous workflow
- ✔ Mesh insert for fine products; Stainless steel insert



Dimensional Drawing

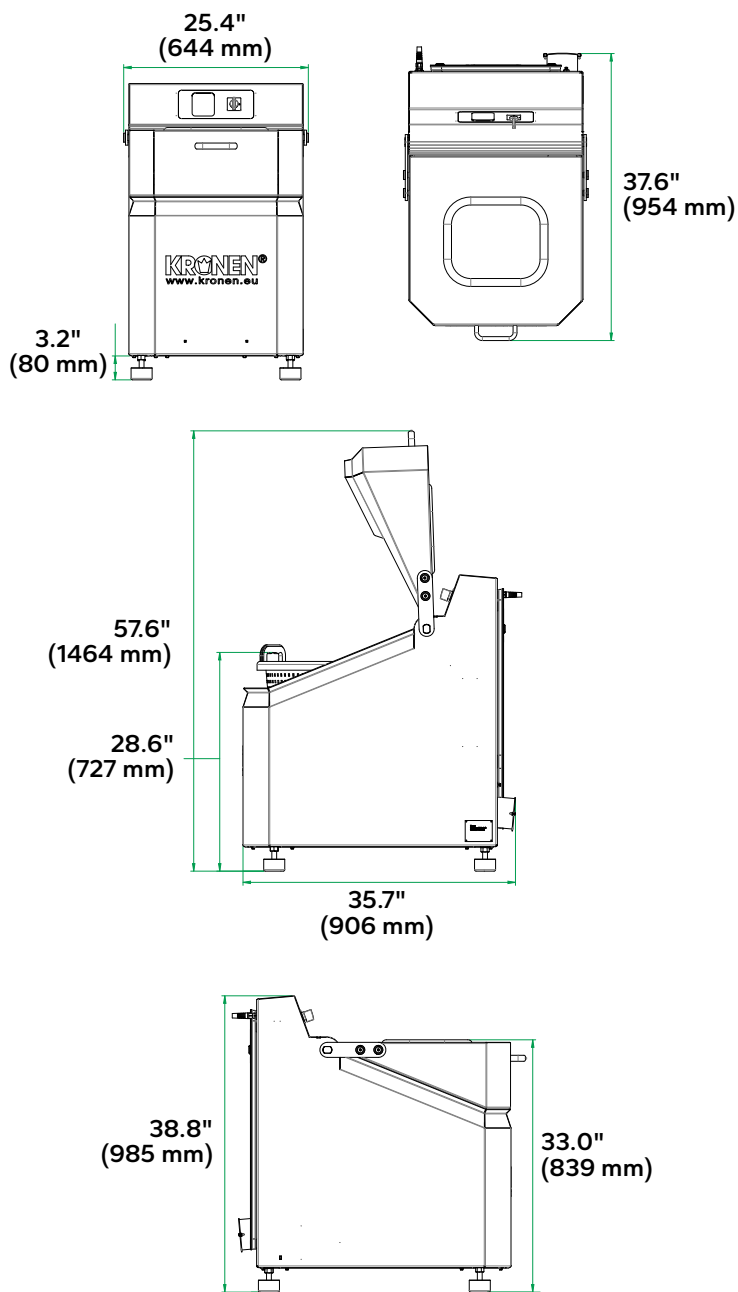

Specifications

Measurements and weights may vary depending on machine configuration.

Electrical	Power: 1.1 HP (0.8 kW) Voltage: 230 V Frequency: 50/60 Hz
Dimensions	LxWxH: 37.6 x 25.4 x 38.8" (954 x 644 x 985 mm) Weight: 350 lb (160 kg)
Additional	Capacity: up to 2,755 lb (1,250 kg)/hr Spin speed: 325–1050 rpm Basket volume: 22 lb (10 kg) or designated fill level of 24" (610 mm) Loading type: Batch



The Global Leader in Food Cutting Technology

#1 Best selling provider
of industrial cutting machinery
throughout the world

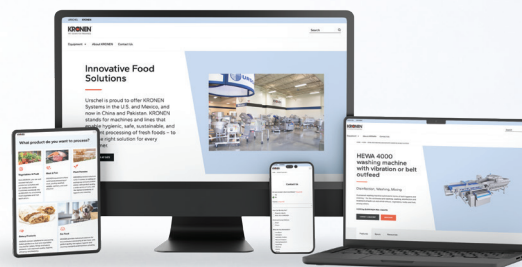

Explore more processing
solutions at urschel.com/kronen.

